

### High Temperature/ High Pressure Cell For Extreme Condition Analyses

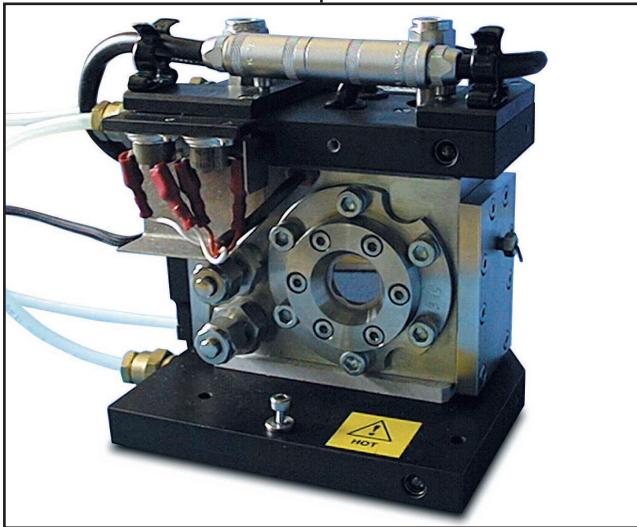

High technology products and modern industrial processes require in-situ analysis under extreme conditions of temperature and pressure.

The ability to recreate these conditions and spectroscopically analyse samples or monitor processes in the laboratory is provided by the Specac High Temperature/High Pressure Cell. The cell has been designed for high optical throughput and allows simple interchange between its multi-purpose analysis configurations, Transmission, Reflectance and Decomposition (Figures 1, 2 and 3).

### Features

- **Extreme Condition Spectroscopy**  
Programmable controlled temperatures up to 800°C and pressures from vacuum to 1000 p.s.i.
- **Multi-purpose Analyzer**  
Transmission, specular reflectance and decomposition.
- **Optimised Design**  
Permits easy interchange between analysis modes
- **Safe and reliable construction**  
Rugged, durable construction incorporating safety approved electronics and safety burst disc

### Applications

- Component failure
- Decomposition studies
- In-situ reaction monitoring
- Surface emissivity measurements
- Process gas analysis

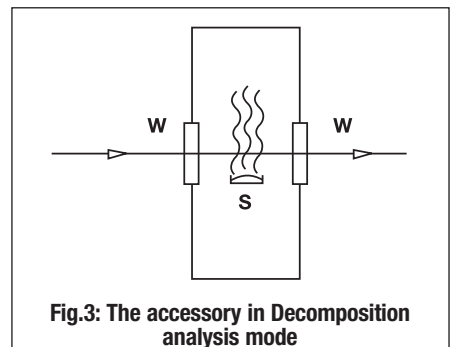
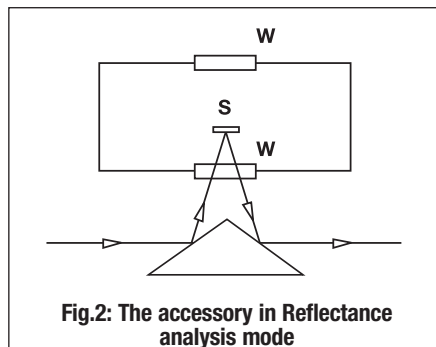
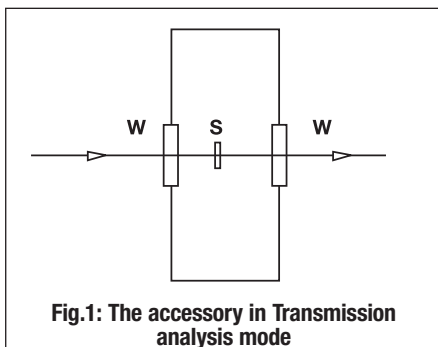

Key: S = Sample W = Window

**The High Temperature/High Pressure Cell permits analysis of solid samples in transmission, specular reflectance and decomposition modes; and process gases in static or flow transmission mode. Sample temperatures of up to 800° C can be achieved and the cell can operate at pressures from vacuum to 1000 p.s.i.**

The cell windows and body are separately heated and controlled up to 200°C to prevent condensation of evolved materials to allow operation as a high pressure heated gas cell. Water cooled top and bottom blocks prevent undue heating of the spectrometer sample compartment and maintain accessible surfaces at a safe temperature.

Switching between transmission (maximum sample diameter 13mm) and specular reflectance modes is achieved by changing optics baseplates. The decomposition mode is obtained by a simple repositioning of the sample holder/heater assembly which places the heated sample in a pan just below the

optical beam. Gases evolved from the sample at different temperatures can then be analysed. The cell has provision for a steady gas flow for either gas analysis or purging. The cell volume is 95ml.

Cell temperature is regulated using a dedicated controller that can be programmed manually or through a computer using the included RS232 interface.

The design incorporates a number of important safety features. In particular, all electrical supplies to the cell comply to Canadian Standards Association (CSA) regulations (30 volts or less) and the temperature controllers are equipped with open circuit detection on the thermocouple inputs to prevent overheating. The cell itself is fitted with a burst disk to prevent inadvertent overpressurisation and, if necessary, this can be piped to a fume cupboard or other outlet point. The cell as standard is ruggedly constructed from durable SS316 stainless steel and can be disassembled if thorough cleaning is required.

## Ordering Information

### **5850 High Temperature/High Pressure Cell System**

Includes: Optical unit with ZnSe windows and instrument baseplate, transmission/decomposition sample holder, programmable high stability temperature controller.

*Please specify spectrometer make and model.*

### **5855 Advanced High Temperature/High Pressure Cell System**

Includes: Optical unit with ZnSe windows and instrument baseplate, transmission/decomposition sample holder, reflectance mode optical assembly, programmable high stability temperature controller.

*Please specify spectrometer make and model.*

**5860** Reflectance mode kit

**5865** Replacement Seal kit

**5867** Replacement ZnSe cell windows (tested and certified)

**5868** Spare set of decomposition boats (3)

**5869** Replacement 'Burst-Disk'

smiths  
A part of Smiths Group plc

# Specac

www.specac.com



**SPECAC LIMITED,**  
River House, 97 Cray Ave, St. Mary Cray,  
Orpington, Kent BR5 4HE U.K.  
Tel : +44 (0)1689 873134  
Fax : +44 (0)1689 878527  
Registered No. 1008689 England

**SPECAC INC.,**  
410 Creekstone Ridge,  
Woodstock, GA 30188 U.S.A.  
Toll Free +1 800 447 2558  
www.specac.com  
Specac is part of Smiths Group plc